

Cessna

specifications



MODEL 140



MODEL 170



MODEL 190

Cessna 190



SPECIFICATIONS

	MODEL 190	MODEL 195A	MODEL 195A SEAPLANE
Engine.....	240 Continental.....	245 Jacobs.....	245 Jacobs.....
Top Speed.....	Over 176 m.p.h.....	Over 160 m.p.h.....	Over 150 m.p.h.....
Cruising Speed.....	Over 160 m.p.h. (@ 7000' 70% power).....	Over 160 m.p.h. (@ 7000' 70% power).....	Over 130 m.p.h. (@ 7000' 70% power).....
Range.....	Over 750 mi. (80 gal.).....	Over 750 mi. (80 gal.).....	Over 600 mi. (80 gal.).....
Rate of Climb.....	1050 ft. per min.....	1050 ft. per min.....	700 ft. per min.....
Service Ceiling.....	16,000 ft.....	16,000 ft.....	14,000 ft.....
Empty Weight.....	2015 lbs.....	2030 lbs.....	2366 lbs.....
Gross Weight.....	3350 lbs.....	3350 lbs.....	3600 lbs.....
Luggage Allowable.....	200 lbs.....	200 lbs.....	200 lbs.....
Wing Loading.....	15.358 lbs./sq. ft.....	15.358 lbs./sq. ft.....	16.5 lbs./sq. ft.....
Power Loading.....	13.958 lbs./h.p.....	13.67 lbs./h.p.....	14.286 lbs./h.p.....
Wing Area.....	218.125 sq. ft.....	218.125 sq. ft.....	218.125 sq. ft.....

STANDARD EQUIPMENT

- | | |
|------------------------------------------------------------------|----------------------------------------|
| Hamilton Standard
Constant Speed
Propeller | Cylinder Temperature
Gauge |
| Stewart-Warner
Thermostatically
Controlled Cabin
Heater | Oil Temperature
Gauge |
| Electrically Heated
Pilot Tube | Oil Pressure Gauge |
| Navigation Lights | Ammeter |
| Landing Light | Carburetor Air
Temperature Gauge |
| Sensitive Altimeter | Dome Light |
| Turn and Bank
Indicator | Map Light |
| Rate of Climb
Indicator | Fluorescent Instrument
Lights |
| Airspeed Indicator | Baggage Compartment
Light |
| Clock | Dual Brakes |
| Compass | Throw-over Control
Wheel |
| Manifold Pressure
Gauge | Parking Brake and
Control Lock |
| Tachometer | Cigarette Lighter and
Ash Receivers |
| Electric Fuel Gauges | Stall Warning
Indicator |

Dynafocal engine suspension, the newest type of engine mounting which more effectively absorbs vibration caused by the engine, reduces cabin sound level.

Optional at Extra Charge—Skis or Floats

C E S S N A
A I R C R A F T C O .
WICHITA, KANSAS, U.S.A.

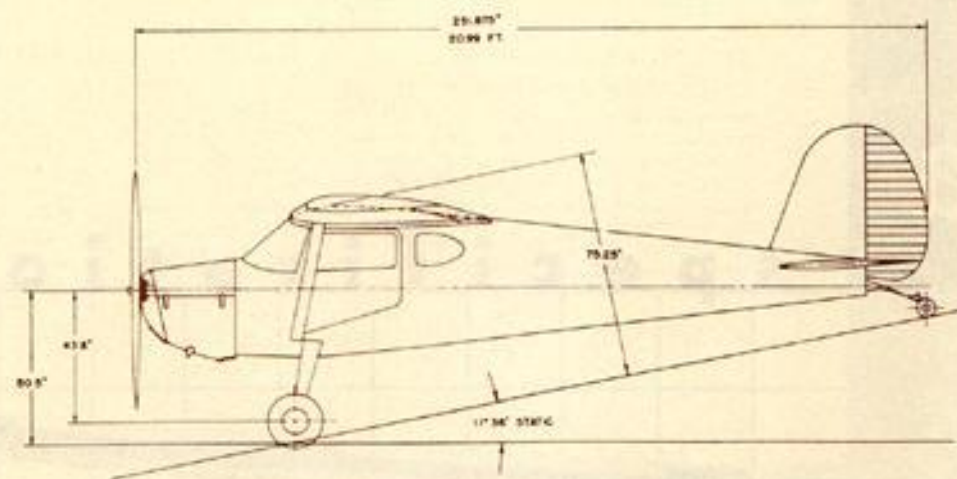

**3-VIEW
MODEL 140**

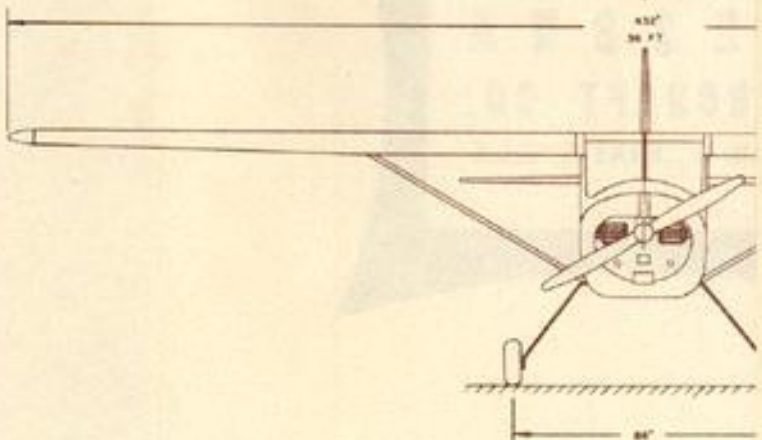
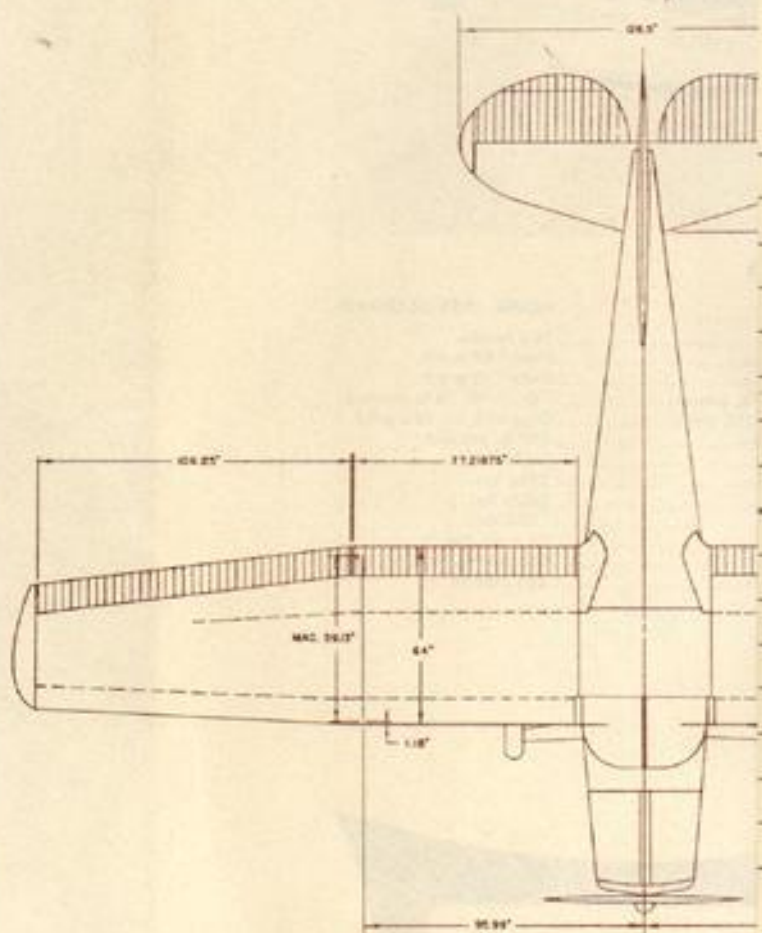
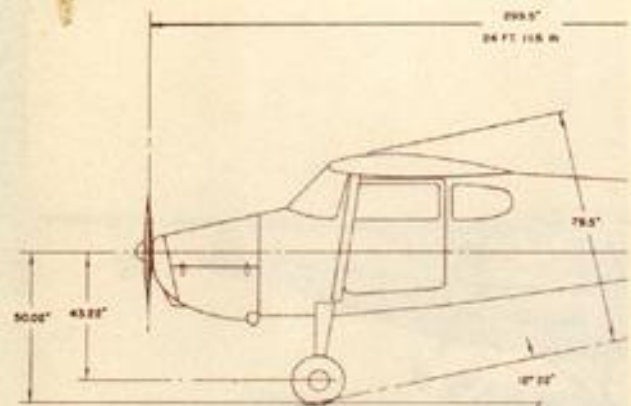
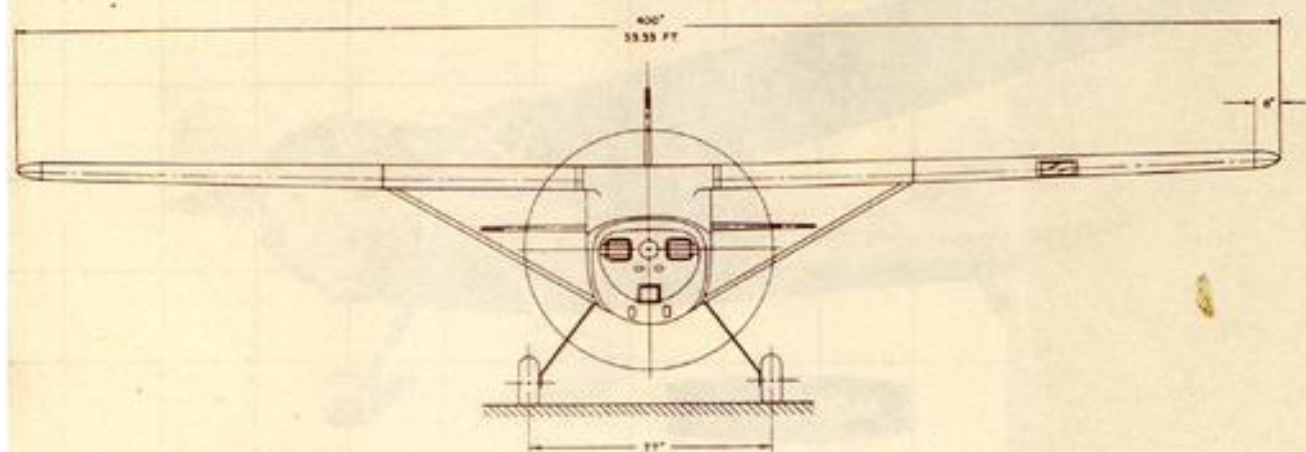
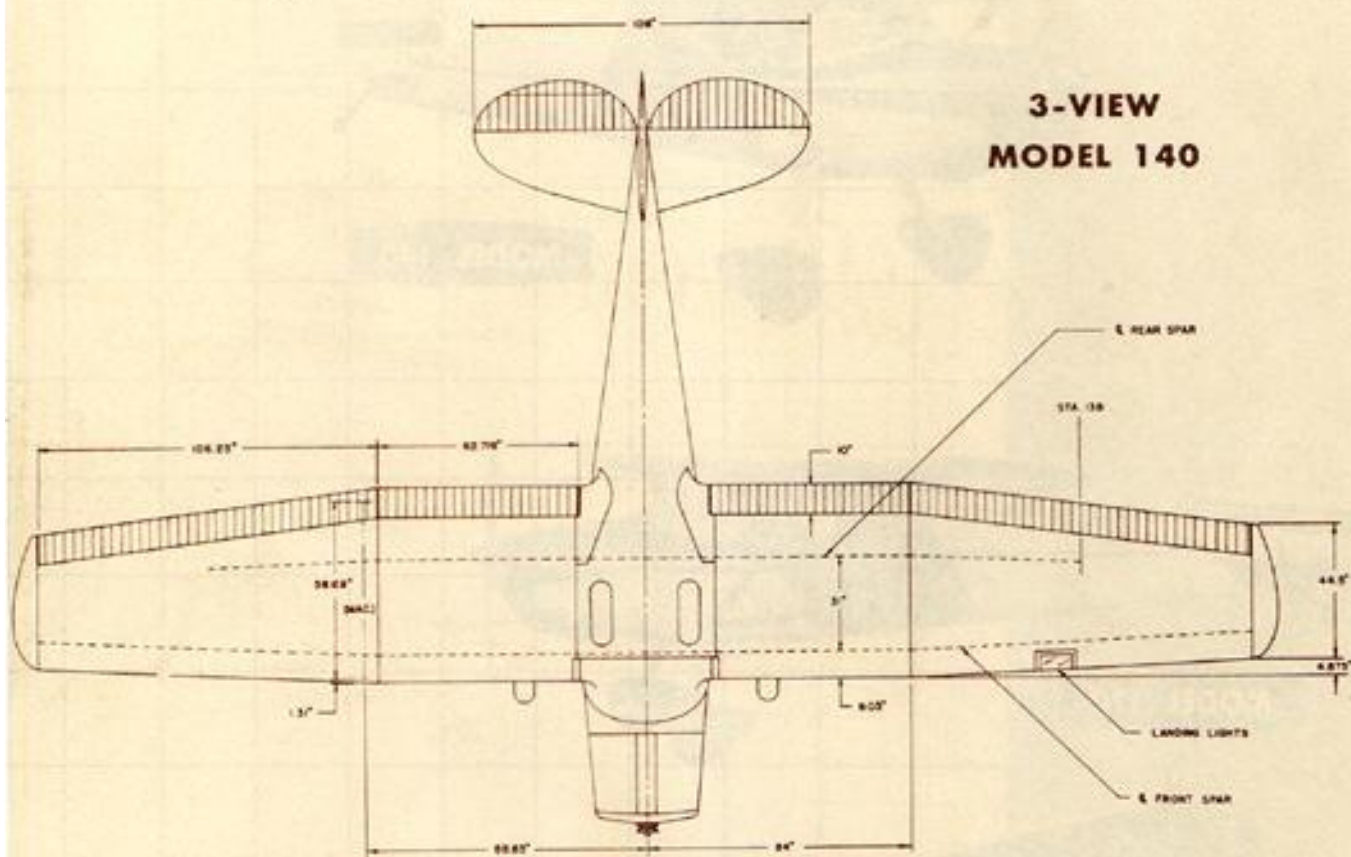

SPECIFICATIONS—140
With McCauley Propeller*

Engine: Continental	90 h.p.	85 h.p.
Top Speed	Over 125 m.p.h.	Over 120 m.p.h.
Cruising Speed	Over 110 m.p.h.	Over 105 m.p.h.
Cruising Range	4 1/2 hours	Over 4 1/2 hrs.
Rate of Climb (sea level)	690 ft. per min.	680 ft. per min.
Service Ceiling	15,600 ft.	15,500 ft.
Landing Speed	41 m.p.h.	41 m.p.h.
Gross Weight	1,500 lbs.	1,500 lbs.
Empty Weight	900 lbs.	900 lbs.
Fuel Capacity	25 gals.	25 gals.
Span	33 ft. 4 in.	33 ft. 4 in.
Length	21 ft. 6 in.	21 ft. 6 in.
Height	6 ft. 3 3/4 in.	6 ft. 3 3/4 in.
Wing Area (inc. fuselage)	159.6 sq. ft.	159.6 sq. ft.
Wing Loading (per sq. ft.)	9.75 lbs.	9.75 lbs.
Power Loading (per h.p.)	16.7 lbs.	17.4 lbs.

STANDARD EQUIPMENT
With 90 h.p.

- | | |
|----------------------------------------------------|--------------------------------------------|
| Ash Tray | Landing Light Wiring and Brackets |
| Airspeed | Map Compartment |
| Altimeter | Mixture Control |
| Ammeter | Navigation Lights |
| Battery (12-volt) | Oil Pressure Gauge |
| Carburetor Air Filter | Oil Temperature Gauge |
| Carburetor Heater | Overhead Windows |
| Cabin Air Vents | Parking Brake |
| Cigarette Lighter | Rear Windows (Two) |
| Compass | Rubber Foam Seat |
| Dome Light | Seat Cushions — No-sag Spring Construction |
| Dual Control Wheels and Rudder Pedals | Shock-Mounted Instrument Panel |
| Engine Mufflers | Stall Warning Indicator |
| Flaps, full adjustable, 43-degree travel | Starter |
| Gas Gauges | Steerable, Full-Swiveling Tail Wheel |
| Generator | Tachometer |
| Hydraulic Brakes—Toe Operated | Tie Down Rings |
| Instrument Lighting, Indirect, Rheostat Controlled | Wood Propeller |

Cessna 140



Cessna 170



SPECIFICATIONS—170

Engine: Continental (6 cyl.)	145 h.p.
Top Speed	Over 140 m.p.h.
Cruising Speed	Over 120 m.p.h.
Cruising Range	Over 4 hrs.
Rate of Climb (sea level)	690 ft. per min.
Service Ceiling	15,500 ft.
Gross Weight	2,200 lbs.
Empty Weight	1,185 lbs.
Fuel Capacity	42 gals.
Span	36 ft.
Length	25 ft.
Height	6 ft. 7 in.
Wing Area	175 sq. ft.
Wing Loading (per sq. ft.)	12.8 lbs.
Power Loading (per h.p.)	15.5 lbs.

STANDARD EQUIPMENT

- | | |
|-------------------------|-----------------------------------|
| Ash Tray | Toe Operated |
| Airspeed | Landing Light Wiring and Brackets |
| Altimeter | Map Compartment |
| Ammeter | Mixture Control |
| Battery | Navigation Lights |
| Carburetor Air Filter | Oil Pressure Gauge |
| Carburetor Heater | Oil Temperature Gauge |
| Cabin Air Vents | Parking Brake |
| Cigarette Lighter | Rubber Air Foam Seat Cushions |
| Compass | Shock Mounted Instrument Panel |
| Dome Light | Spacer |
| Dual Control Wheels | Starter |
| Dual Brakes | Steerable Full Swivel Tail Wheel |
| Engine Mufflers | Tachometer |
| Gravity Fuel System | Tie Down Rings |
| Stall Warning Indicator | Tachometer |
| Gas Gauges | Wood Propeller |
| Generator | Wing Flaps |
| Heater | |
| Hydraulic Brakes— | |

Wheel Pants Optional at Extra Cost

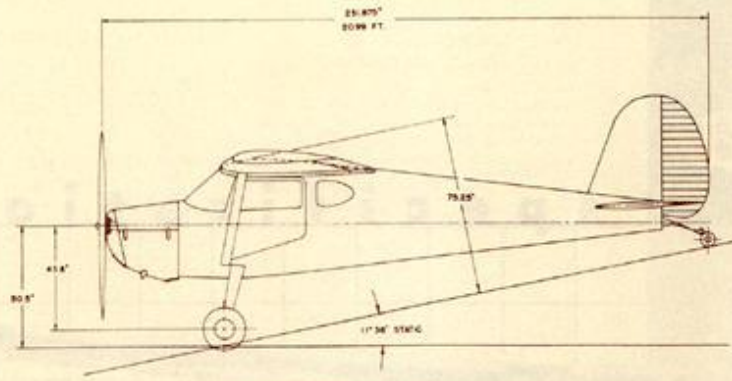

**3-VIEW
MODEL 140**

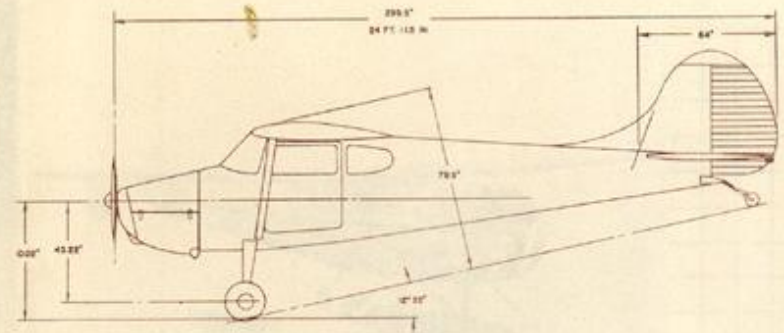
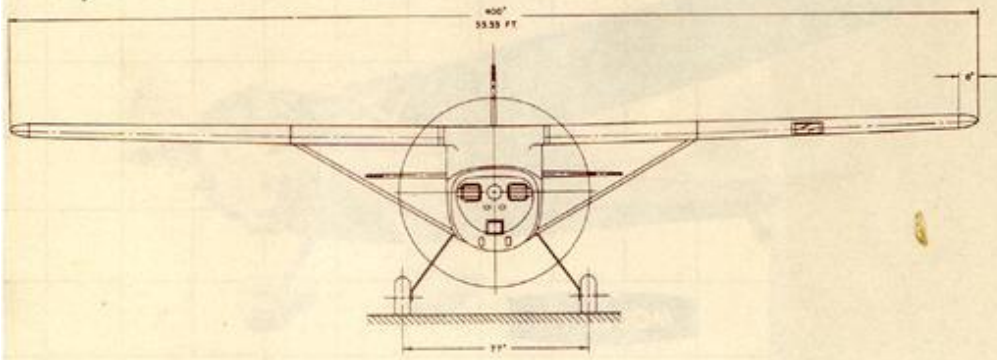
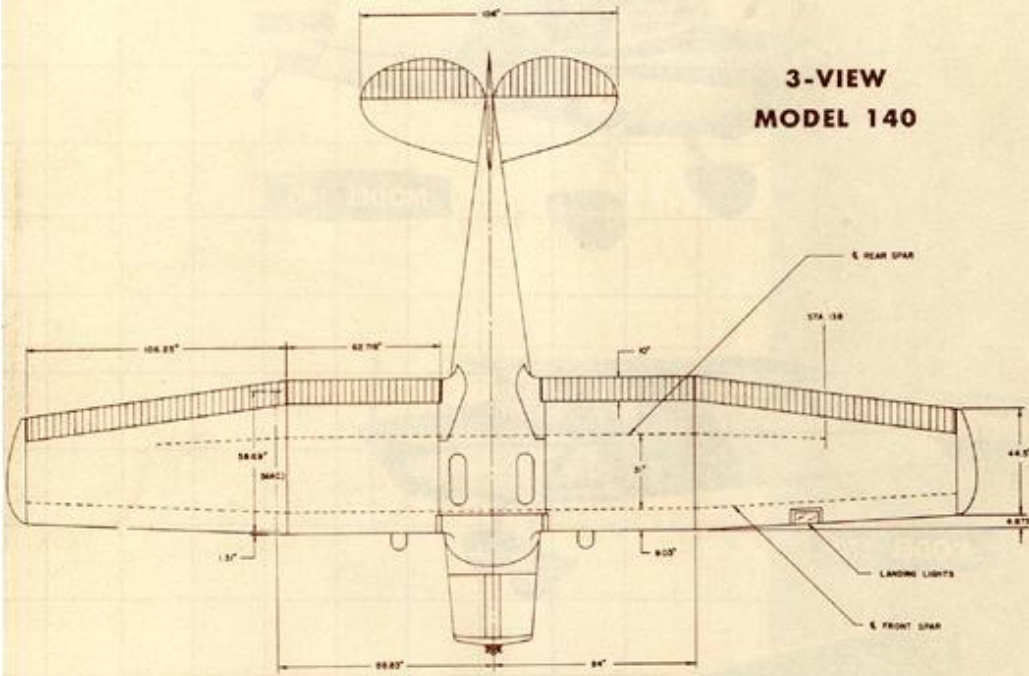

**3-VIEW
MODEL 170**

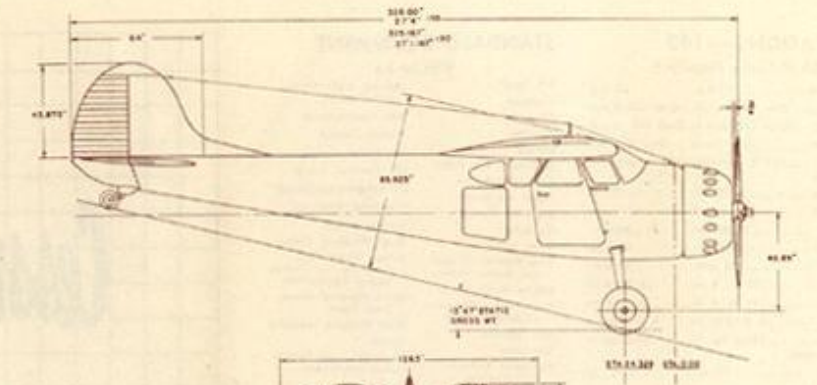
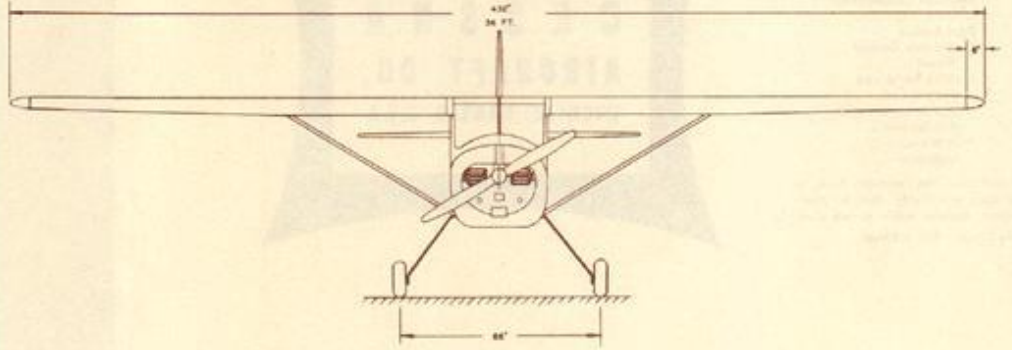
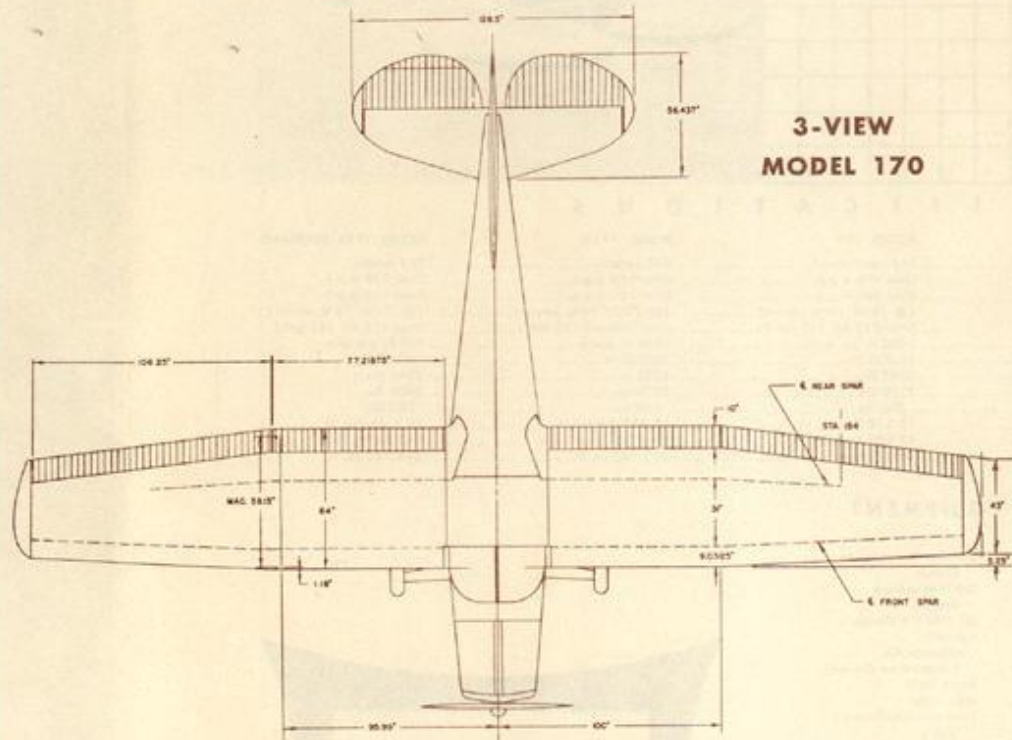

**3-VIEW
MODEL 190
SERIES**

